

# FRIGID FLUID CO - LOWERING DEVICE STAND

## - NON-TELESCOPING MODEL

PARTS NOT INCLUDED ON DIAGRAM:  
 4-STD12 - SPRING FOR DRAPERY TUBE BUSHING (#10 ON DIAGRAM)  
 4-STD21 - SPRING FOR CONNECTING TUBE BUSHING (#5 ON DIAGRAM)

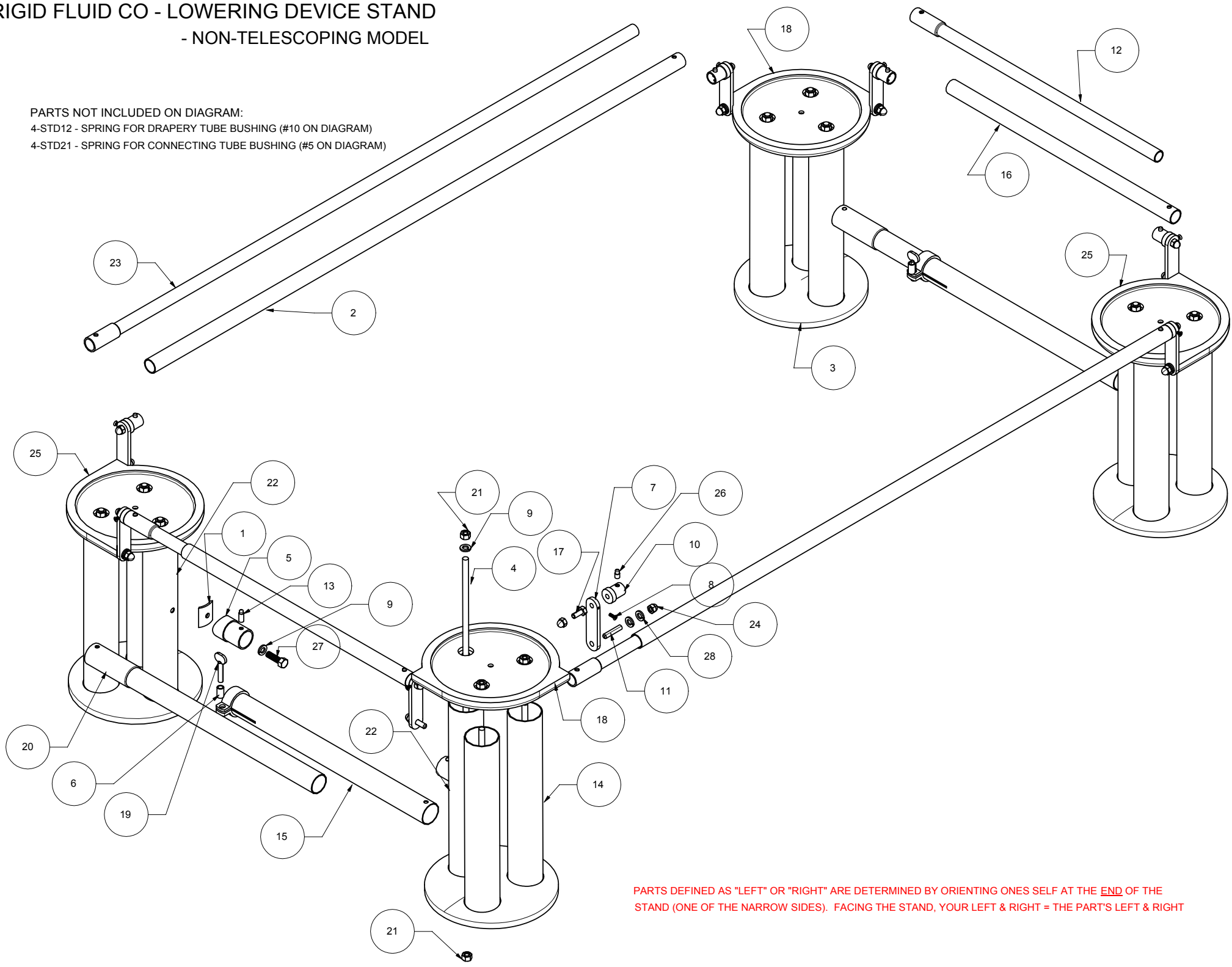

PARTS DEFINED AS "LEFT" OR "RIGHT" ARE DETERMINED BY ORIENTING ONES SELF AT THE END OF THE STAND (ONE OF THE NARROW SIDES). FACING THE STAND, YOUR LEFT & RIGHT = THE PART'S LEFT & RIGHT

Number	Part # - Aluminum Stand	Part # - Stainless Stand	Description	Quantity
1	4-STD17	<-- same	CONNECTING TUBE BUSHING MATE - BRASS	4
2	4-STD32	<-- same	INSIDE SIDE DRAPE TUBE	2
3	4-STD01B	<-- same	BASE PLATE	4
4	4-STD04	<-- same	TIE ROD FOR POST TUBES	12
5	4-STD19	<-- same	CONNECTING TUBE BUSHING	4
6	4-STD26SLV	<-- same	SLEEVE FOR CONNECTING TUBE THUMB SCREW	2
7	4-STD06	<-- same	DRAPE ROD FINGER	8
8	4-CTP03D	<-- same	SCREW FOR DRAPE HOOK	8
9	4-STD04A	<-- same	LOCK WASHER	16
10	4-STD11	<-- same	DRAPE ROD FINGER BUSHING	8
11	4-STD08	<-- same	THREADED STUD FOR FINGER	8
12	4-STD28	<-- same	OUTSIDE END DRAPE TUBE	2
13	4-STD22	<-- same	BUTTON FOR CONNECTING TUBE BUSHING	4
14	4-STD03	4-STD03S	13" POST TUBE - ALUM. OR STAINLESS	8
15	4-STD25	<-- same	OUTSIDE CONNECTING TUBE	2
16	4-STD29	<-- same	INSIDE END DRAPE TUBE	2
17	4-STD14	<-- same	BOLT FOR DRAPE ROD BUSHING	8
18	4-STD02R	<-- same	TOP FLANGE - RIGHT	2
19	4-STD26	<-- same	THUMB SCREW	2
20	4-STD24	<-- same	INSIDE CONNECTING TUBE	2
21	4-STD04P	<-- same	HEX NUT	24
22	4-STD03B	4-STD03BS	13" POST W/ BUSHING - ALUM. OR STAINLESS	4
23	4-STD31	<-- same	INSIDE SIDE DRAPE TUBE	2
24	4-STD15	<-- same	ACORN NUT	16
25	4-STD02L	<-- same	TOP FLANGE - LEFT	2
26	4-STD13	<-- same	BUTTON FOR DRAPE ROD BUSHING	8
27	4-STD18	<-- same	HEX BOLT FOR CONNECTING TUBE BUSHING	4
28	4-STD09	<--same	LOCK WASHER	16