

# Lowering device hand stop brake

BLUE PARTS = 4-BRK179I or 4-BRK179M

15

BRAKE STAND, BASE, SHOE & LEATHER COMPLETE

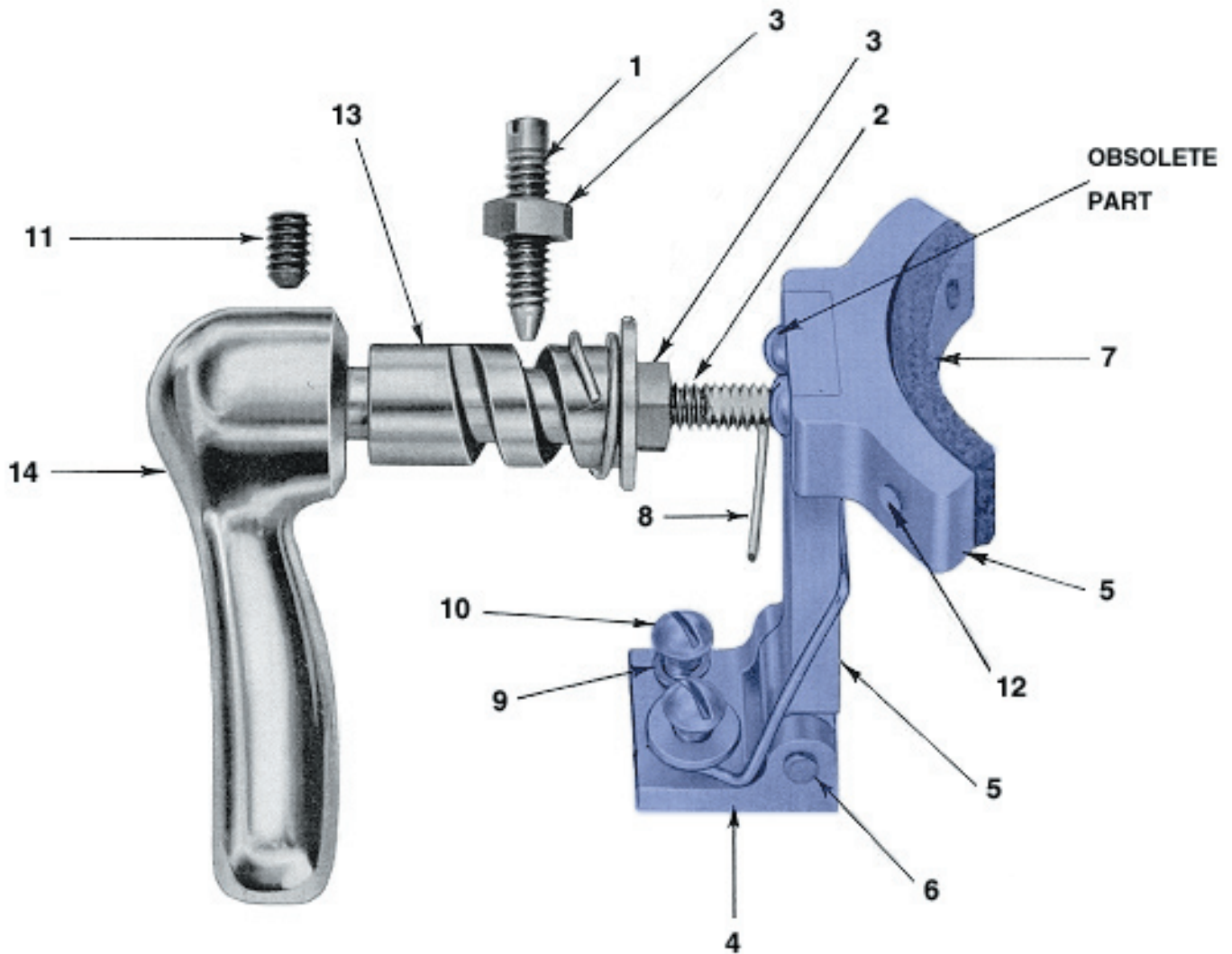

## Brake Parts

No.	Imperial Item #	Master Item #	Description
1	4-BRK169I	4-BRK169M	WORM RETAINING SET SCREW WITH LOCK NUT
2	4-BRK170I	4-BRK170M	HAND BRAKE SHAFT PLUNGER STUD WITH LOCK NUT
3	4-BRK171	4-BRK171	1/4 - 20 HEX, LOCK NUT (USED ON WORM & STUD)
4	4-BRK172	4-BRK172	HAND BRAKE SHOE BASE W/ BASE SCREWS & WASHERS
5	4-BRK173/74	4-BRK173/74	HAND BRAKE SHOE & STAND WITH SCREWS
6	4-BRK176	4-BRK176	HAND BRAKE SHOE BASE PIN
7	4-BRK177	4-BRK177	HAND BRAKE SHOE LEATHER WITH STRIP SCREWS
8	4-BRK178I	4-BRK178M	HAND BRAKE SHOE SPRING
9	4-BRK231	4-BRK231	HAND BRAKE LOCK WASHERS #10 (2)
10	4-BRK232I	4-BRK232M	HAND BRAKE SHOE BASE SCREW
11	4-BRK234	4-BRK234	HAND BRAKE HANDLE SET SCREW
12	4-BRK49	4-BRK49	HAND BRAKE SHOE LEATHER STRIP SCREW (2)
13	4-BRK54	4-BRK54	HAND BRAKE SHAFT
14	4-BRK57	4-BRK57	HAND BRAKE HANDLE WITH SET SCREW
15	4-BRK179I	4-BRK179M	BRAKE STAND, BASE, SHOE & LEATHER COMPLETE