



ASSEMBLY INSTRUCTIONS FOR CEMETERY MODEL LOWERING DEVICES

MASTER AND IMPERIAL

IMPERIAL MODEL DISPLAYED THROUGHOUT THIS DIAGRAM

PLAIN PACKAGE

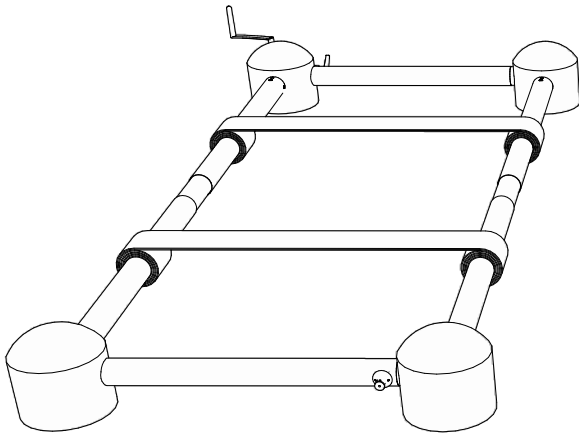

PLACER SET PACKAGE

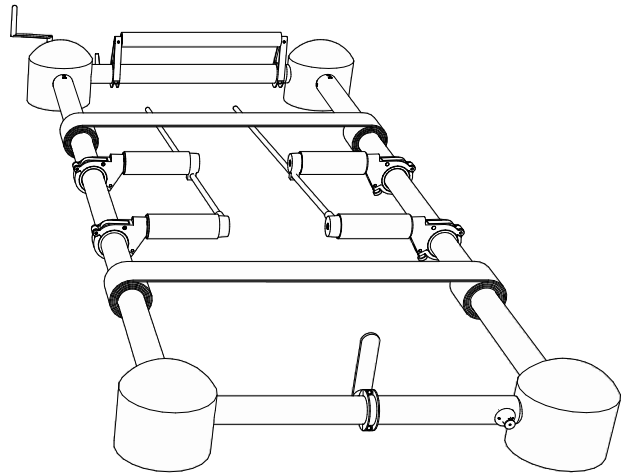

FRIGID FLUID COMPANY
11631 W. GRAND AVENUE
NORTHAKE, IL 60164

1-708-836-1215

www.frigidfluidco.com/device

STEP 1:

LAYOUT EACH COMPONENT OF THE DEVICE AS SHOWN .

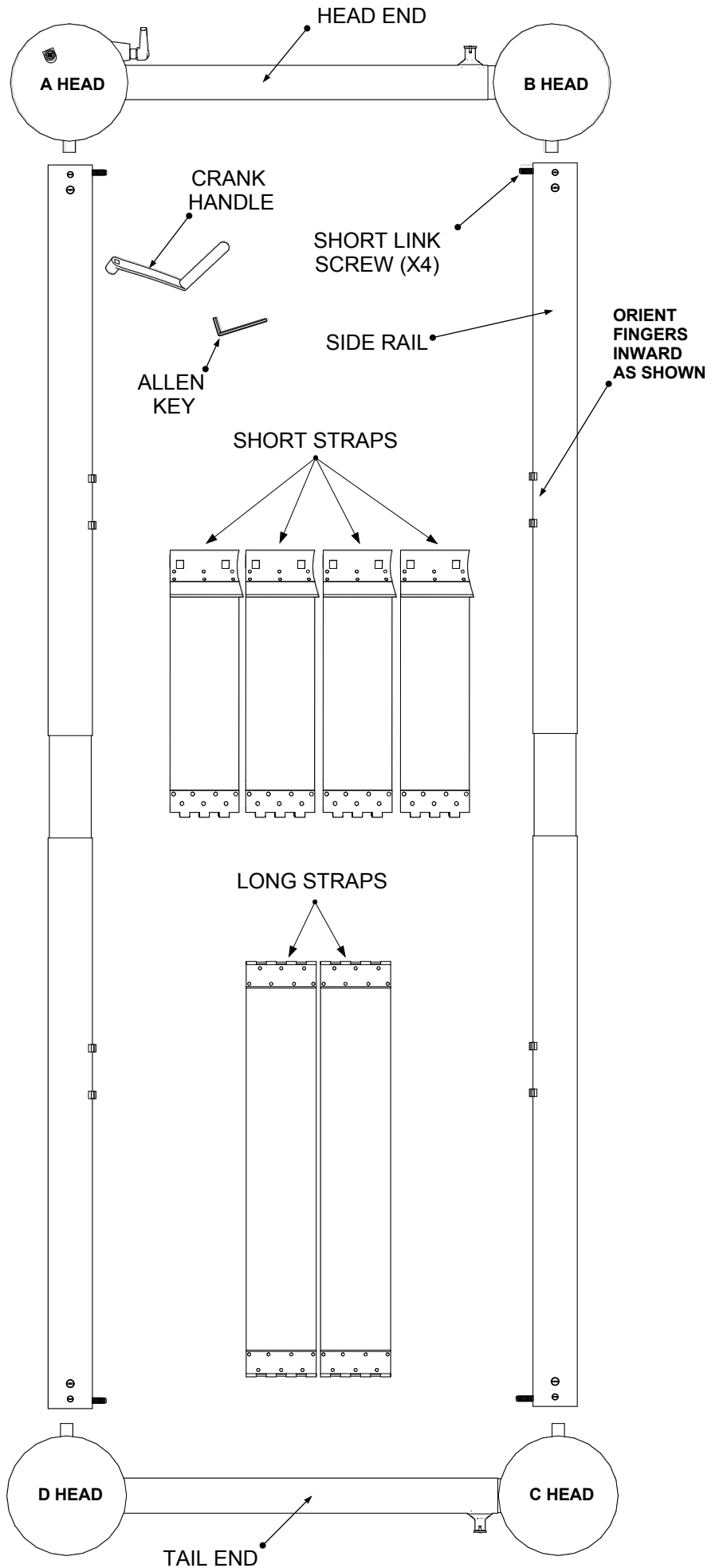
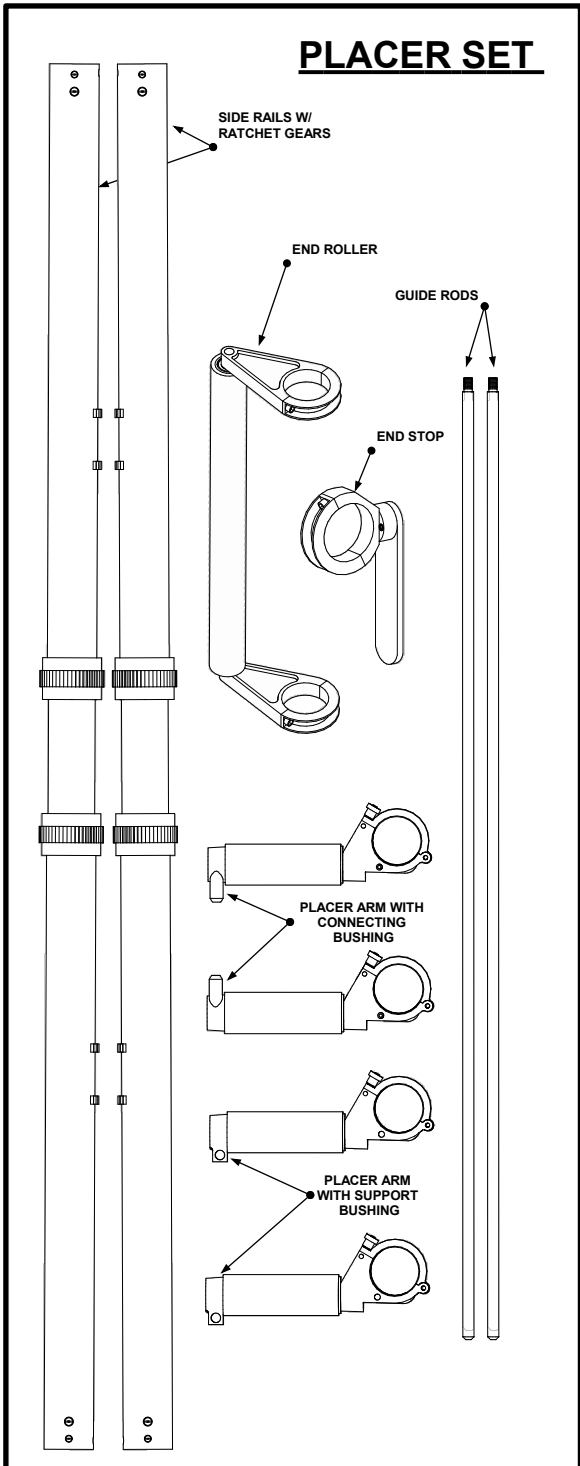

STEP 2:

REMOVE EACH SHORT LINK SCREW ON BOTH ENDS OF EACH SIDE RAIL WITH ALLEN KEY.

***DO NOT
LOOSEN OR
REMOVE
THESE
SCREWS**

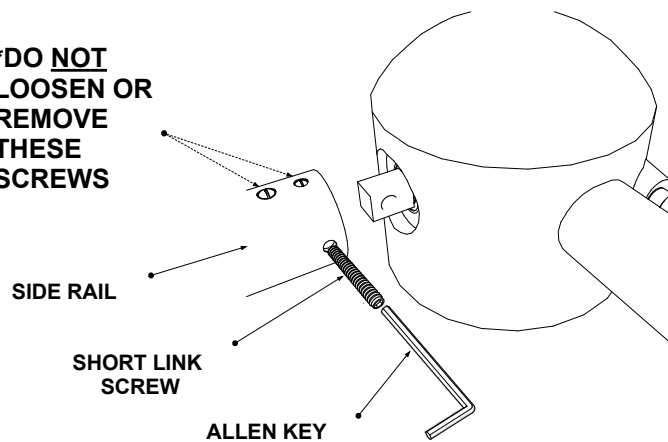

STEP 3:

ON THE HEAD END POSITION THE HAND BRAKE INTO THE OFF POSITION.

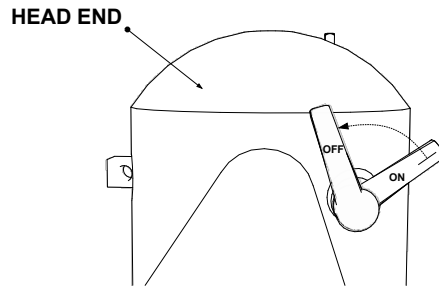

STEP 4:

WITH THE BRONZE CRANK HANDLE, TURN THE WORM SHAFT COUNTER CLOCKWISE UNTIL THE SHORT LINK IS ORIENTED AS SHOWN.

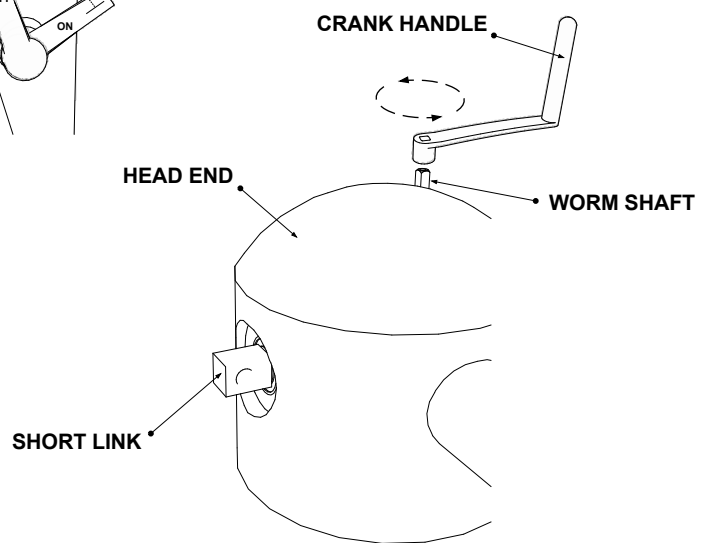

STEP 5:

PLACE THE ENDS OF EACH SIDE RAIL ONTO EACH SHORT LINK UNTIL BOTH OF THE SHORT LINK SCREW HOLES ARE ALLIGNED.

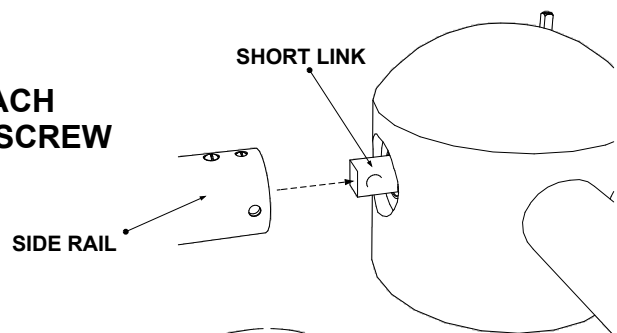

STEP 6:

INSERT THE SHORT LINK SCREW WITH THE ALLEN KEY. THE TOP OF THE SCREW SHOULD BE JUST BELOW THE PLANE OF THE SIDE RAIL ONCE FULLY INSERTED.

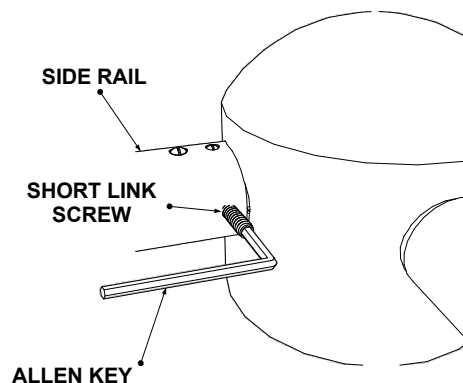

STEP 7:

PLACE EACH OF THE FOUR SHORT STRAPS ONTO THE SIDE RAIL FINGERS AS SHOWN.

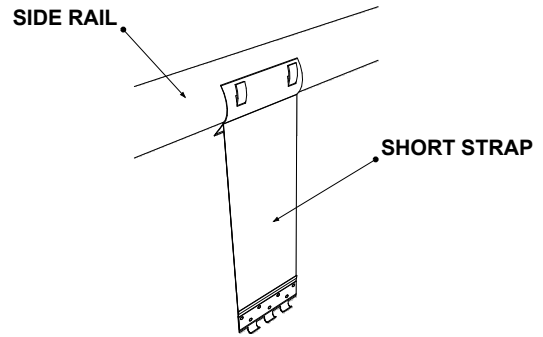

STEP 8:

ATTACH EACH END OF THE LONG STRAPS TO THE HOOKS ON THE SHORT STRAPS AS SHOWN.

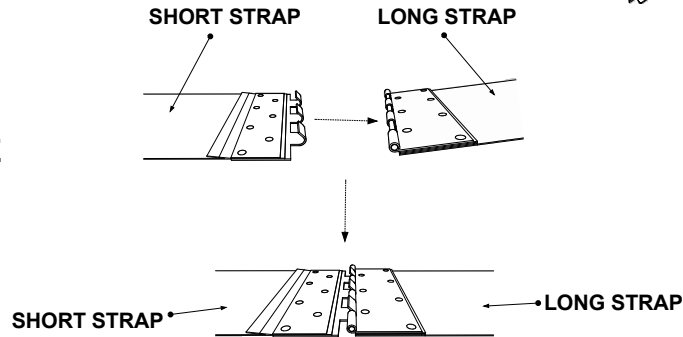

STEP 9:

WITH BOTH HANDS, GRIP EITHER SIDE RAIL FROM THE OUTSIDE BETWEEN THE FINGERS AND SLOWLY TURN OUTWARD TO WIND UP THE STRAPS UNTIL THEY ARE TAUT. BE CAREFUL TO KEEP THE STRAPS FROM TWISTING AS YOU ARE WINDING.

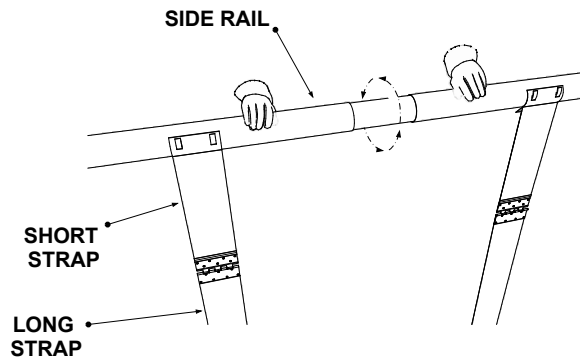

STEP 10:

PLACE THE HAND BRAKE BACK INTO THE ON POSITION. MAKE SURE THERE IS A SMALL AMOUNT OF SLACK IN THE STRAPS TO AVOID BENDING THE SIDE RAILS.

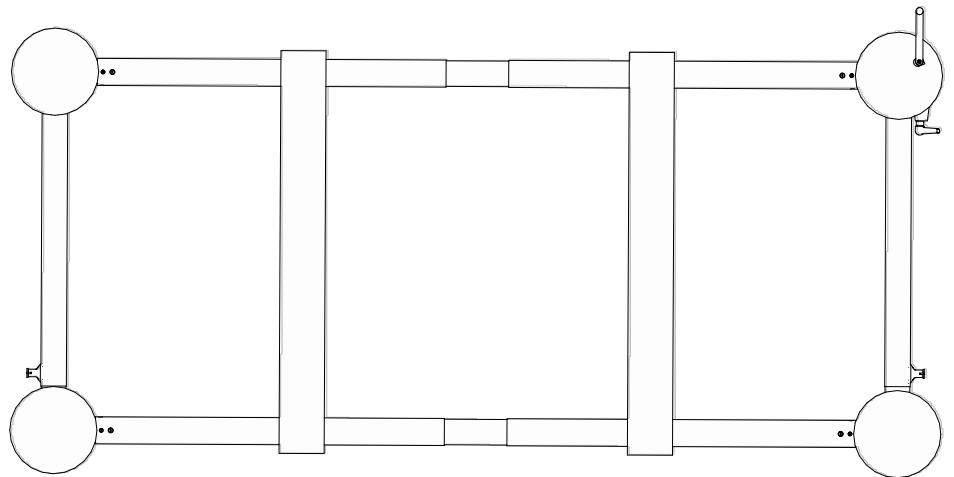

** IF YOUR DEVICE IS A **PLAIN** CEMETERY MODEL, YOU HAVE COMPLETED THE REQUIRED ASSEMBLY. CONGRATULATIONS.*



** FINISH THE REMAINING STEPS IF YOUR DEVICE HAS A **PLACER SET**.*

STEP 1:

WITH THE ALLEN KEY, REMOVE THE TWO CAPS FROM EACH END OF THE END ROLLER. TO ACHIEVE THE BEST FIT IN STEP #2, BE SURE TO NOTE WHICH END EACH CAP WAS REMOVED FROM.

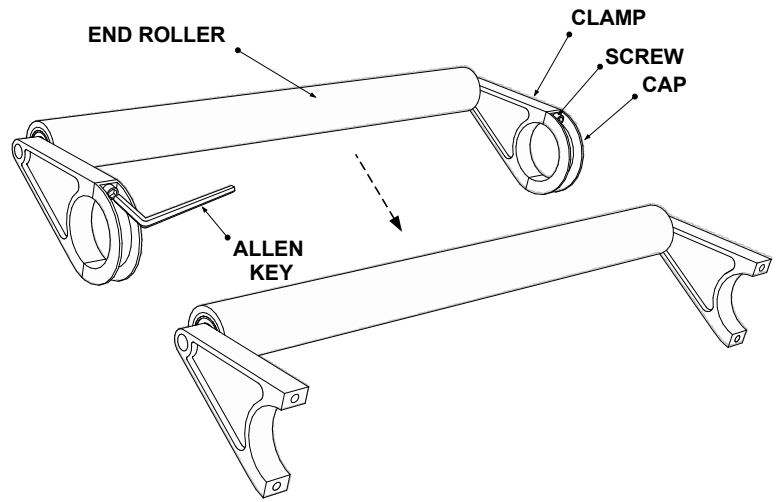

STEP 2:

POSITION THE END ROLLER ONTO THE HEAD END AS SHOWN. WITH THE ALLEN KEY, RE-ATTACH EACH CAP TO THE CLAMP IT WAS REMOVED FROM.

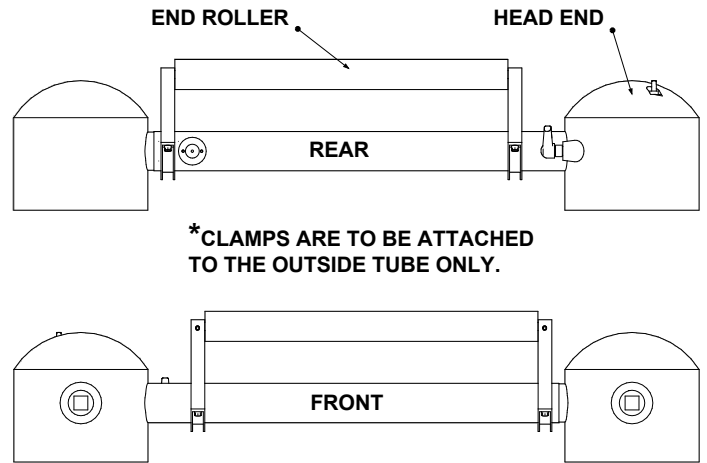

STEP 3:

REPEAT STEPS 1 AND 2 TO ATTACH THE END STOP TO THE TAIL END AS SHOWN.

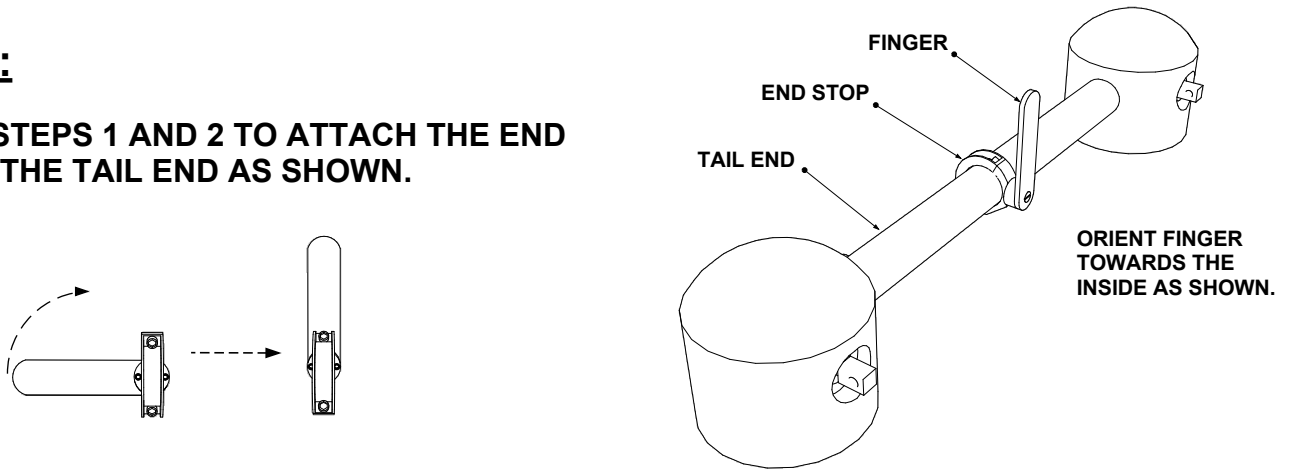

STEP 4:

ON ALL 4 PLACER ARMS, LOOSEN THE NUT AND OPEN THE CLAMP AS SHOWN.

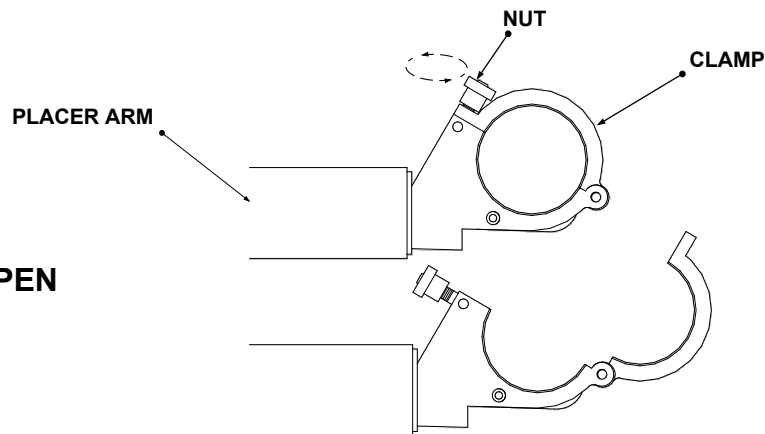

STEP 5:

LOCATE THE 2 PLACER ARMS THAT HAVE THE SUPPORT BUSHINGS AND SECURE EACH INTO POSITION A (AS SHOWN) ONTO EACH OF THE SIDE RAIL RATCHET GEARS *CLOSEST TO THE HEAD END*. THEN ROTATE THE PLACER ARM INWARD INTO POSITION B.

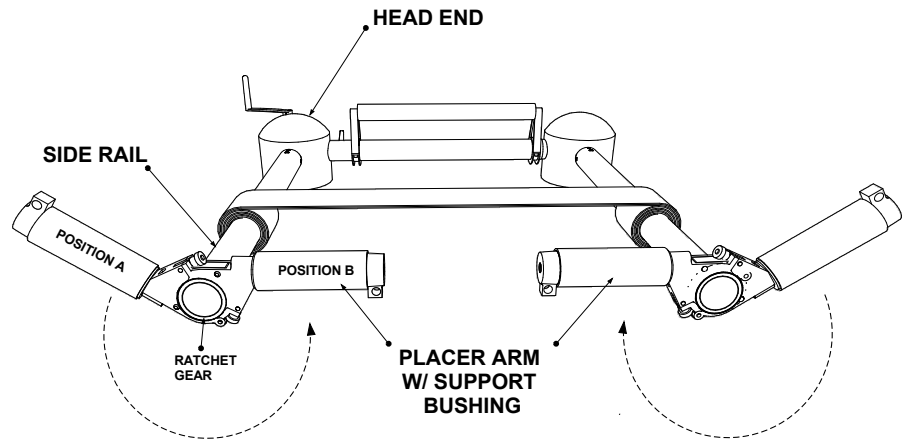

STEP 6:

REPEAT STEP 5 WITH THE TWO REMAINING PLACER ARMS WITH THE CONNECTING BUSHINGS ON THE TWO REMAINING SIDE RAIL RATCHET GEARS. THE BUSHINGS SHOULD BE ORIENTED AS SHOWN.

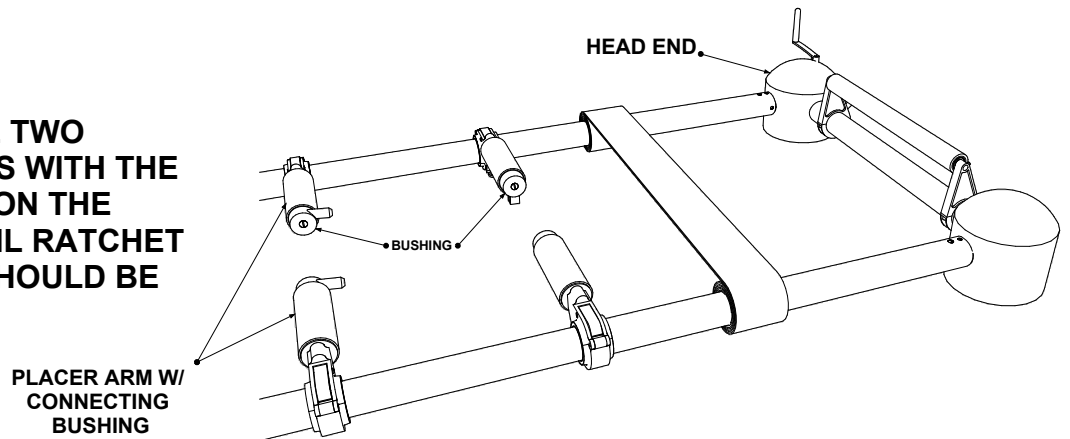

STEP 7:

WITH THE THREADED END FIRST, SLIDE EACH GUIDE ROD THROUGH THE BUSHING OF EACH PLACER ARM. THEN SECURELY TIGHTEN THE THREADED END INTO THE BUSHING ON EACH PLACER ARM.

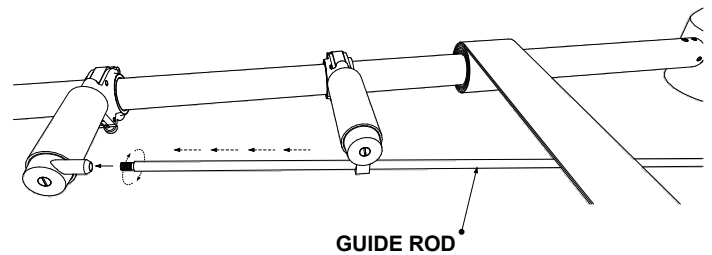

***BE SURE TO POSITION THE GUIDE RODS UNDER THE STRAPS AS SHOWN.**

STEP 8:

YOUR DEVICE IS NOW FULLY ASSEMBLED AND READY FOR USE.

